



**WACKER
NEUSON**
all it takes!

Compact and wheeled excavators

6 to 15 t



Your reliable solution provider

We offer customers worldwide with a comprehensive product range of construction machines and equipment, spare parts and services. Since the beginnings of our company in 1848, Wacker Neuson brand has stood for reliability and innovative strength. Companies in the main construction industry, gardening and landscaping, industry and municipalities, among other sectors, rely on the innovative solutions from Wacker Neuson.

Wacker Neuson – **all it takes!**



Our services

When you need us, we are there. We not only advise you during the purchase of a machine, but also afterwards. You can trust our expert and quick support. Find out about our extensive services for construction machines and construction equipment. With our widespread sales and service network, we are always close by.

Experience more:
wackerneuson.com/services



Contents.

Tracked excavators ET65, EZ80 and ET90	4
Tracked excavator ET145	14
Wheeled excavator EW65	20
Wheeled excavator EW100	26
Attachments	36
Configuration options	38
Dimensions	40
Technical data	41
Lifting power tables	42

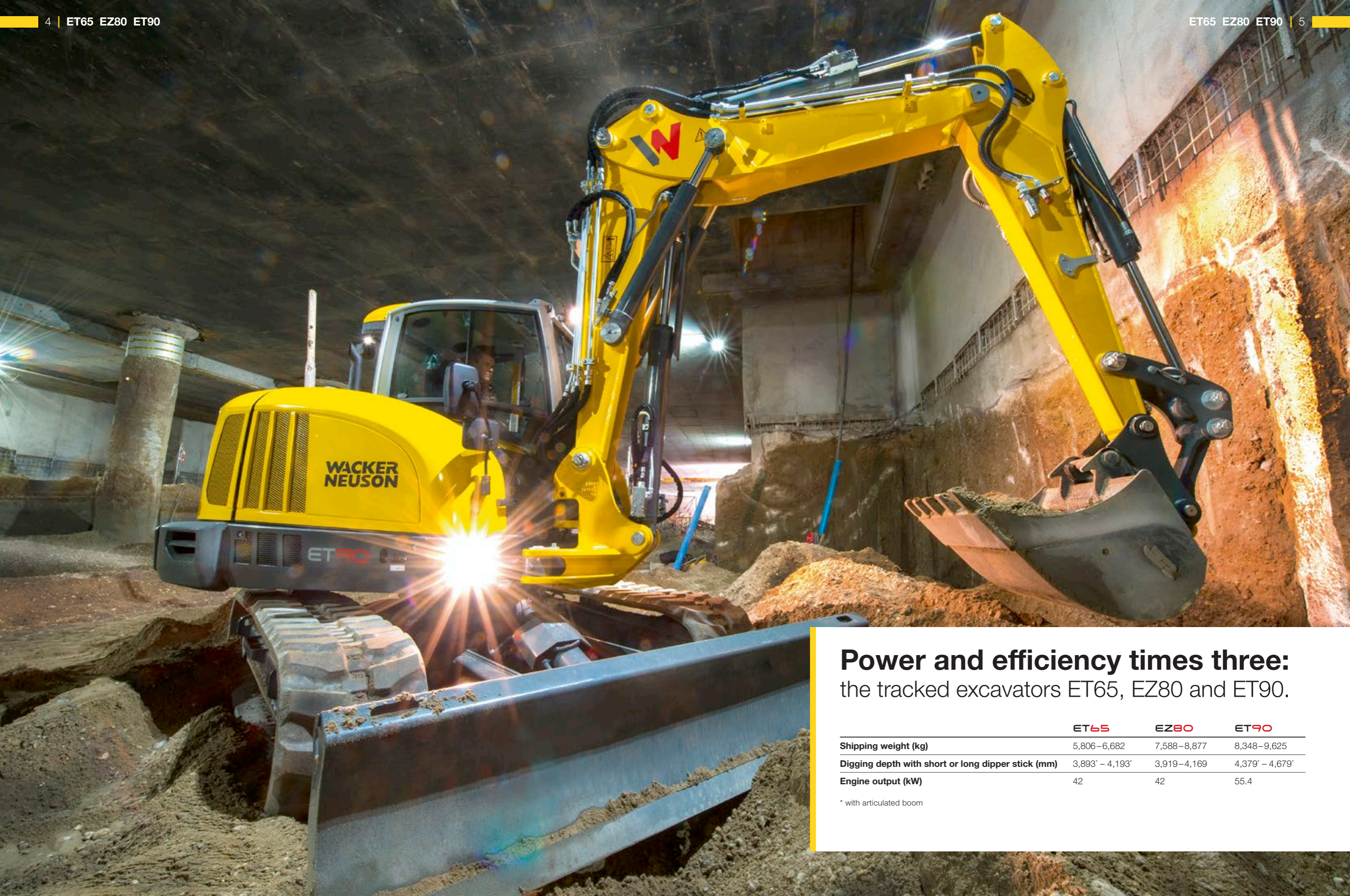

Power and efficiency times three: the tracked excavators ET65, EZ80 and ET90.

	ET65	EZ80	ET90
Shipping weight (kg)	5,806–6,682	7,588–8,877	8,348–9,625
Digging depth with short or long dipper stick (mm)	3,893* – 4,193*	3,919–4,169	4,379* – 4,679*
Engine output (kW)	42	42	55.4

* with articulated boom

Economical and powerful.

An overview of all the features of the ET65, EZ80 and ET90.

Quality

- Short hydraulic hoses for less power loss and a long service life
- Large and sturdy aluminum radiator, easy to clean, and with the best cooling performance in its class
- High stability due to a low center of gravity and optional additional rear counterweight

Maintenance

- Quick and easy to access maintenance points

Safety

- Up to seven LED headlights around the machine for optimal illumination of the work area
- Eight large tie-downs for safe transport

Versatility

- No rear projection thanks to the Zero Tail (EZ80)
- Depending on the model, different track versions to choose from



Efficiency

- Articulated boom for greater digging radius and less repositioning (optional with ET65 and ET90)
- Powerful drive system for high performance
- Precise control with any load thanks to load-sensing hydraulic system with LUDV (load-independent flow distribution)
- Thermal stability enables 100% power with an ambient temperature of up to 45°C

Comfort

- Spacious comfort cabin that can be adjusted to any operator size
- Intuitive operating concept enables the simple and comprehensive control of the excavator
- Compact and maneuverable due to intelligent arrangement of the components and low height of machine
- Low tank filler point for easy refueling without climbing

Performance

- Up to four optional auxiliary control circuits ex works
- 3-point kinematics for 200° bucket rotation angle and improved digging data and reach
- Two operating modes to choose from: full power (POWER) or fuel-saving (ECO)

Environmental-friendliness

- Low engine noise enables easier communication on the construction site
- Diesel particulate filter to meet country-specific, statutory emission regulations

Our three economic miracles.

Strong performance: All three excavators consume up to 20% less fuel than comparable models. Nevertheless, they are best in their class within the range of digging power and break out force. We promised you a miracle.

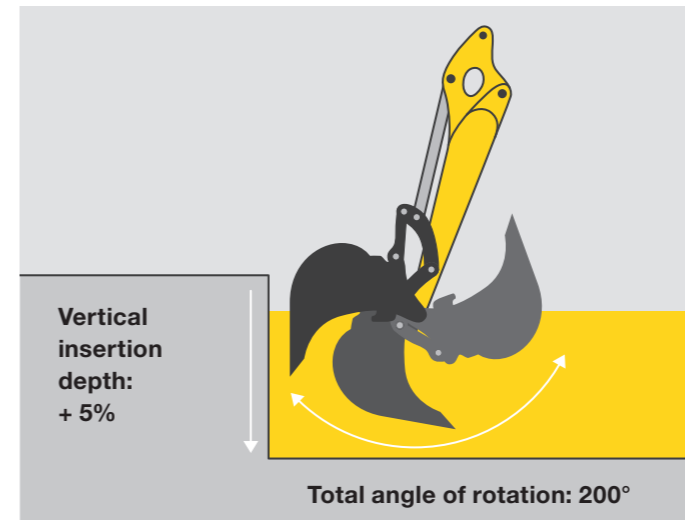

Unique 3-point kinematics.

The higher torque or the 3-point kinematics as well as the 200°-expanded angle of rotation make the ET65 and ET90 the best in their class in terms of digging power.

- Optimal insertion angle rotation of the bucket
- Digs even deeper vertically
- More powerful excavating
- Improved dumping behavior and less material loss
- Up to 20% more break out force



More productivity and less consumption.

With independent flow distribution (LUDV), 3-point kinematics (ET65, ET90), an articulated boom, and long dipper stick, you will be able to get the maximum out of your machine. Due to the efficient hydraulics and the appropriate, mechanical foundation for



More leeway thanks to articulated boom.

The articulated boom provides you with more maneuverability and therefore greater freedom of action. Because the additional joint permits the bucket to be pulled right up to the travel gear or the dozer blade. Ideal when narrow spaces need to be accessed or an obstacle has to be moved out of the way. The articulated boom is optionally available with the ET65 and ET90, and available with a short or long dipper stick.



this, the machine is streamlined to high productivity. This ensures up to 30% more productivity on the construction site, despite possible fuel savings of up to 20%. Achieve more with fewer costs - three machines for the highest degree of efficiency.

More cabin comfort.

The ergonomically optimized operator cabin of the ET65, EZ80, and ET90.

Maximum operating comfort is standard with the ET65, EZ80 and ET90. In addition, we offer you numerous options to adjust the excavator to your individual requirements.

Performance

- User-friendly Jog Dial with individually savable settings
- Very low noise levels in the closed cabin
- Two-part windshield that can be completely slid under the cabin roof (standard equipment)

Comfort

- Front sun blind, as standard
- Comfortable and intuitive joystick operation concept: with all important functions on both joysticks
- Powerful air-conditioning system for a pleasant working temperature at all times
- Fully-lined cabin interior with a variety of storage compartments
- Air-cushioned comfort seat including seat heating for increased operator comfort and height adjustment

Safety

- Optimal visibility due to the offset arm position
- Large skylight for the best view even upwards
- Lateral sliding window
- LED headlights for even better illumination
- Rear-view camera with 7" multi-functional display for an ideal view to the rear

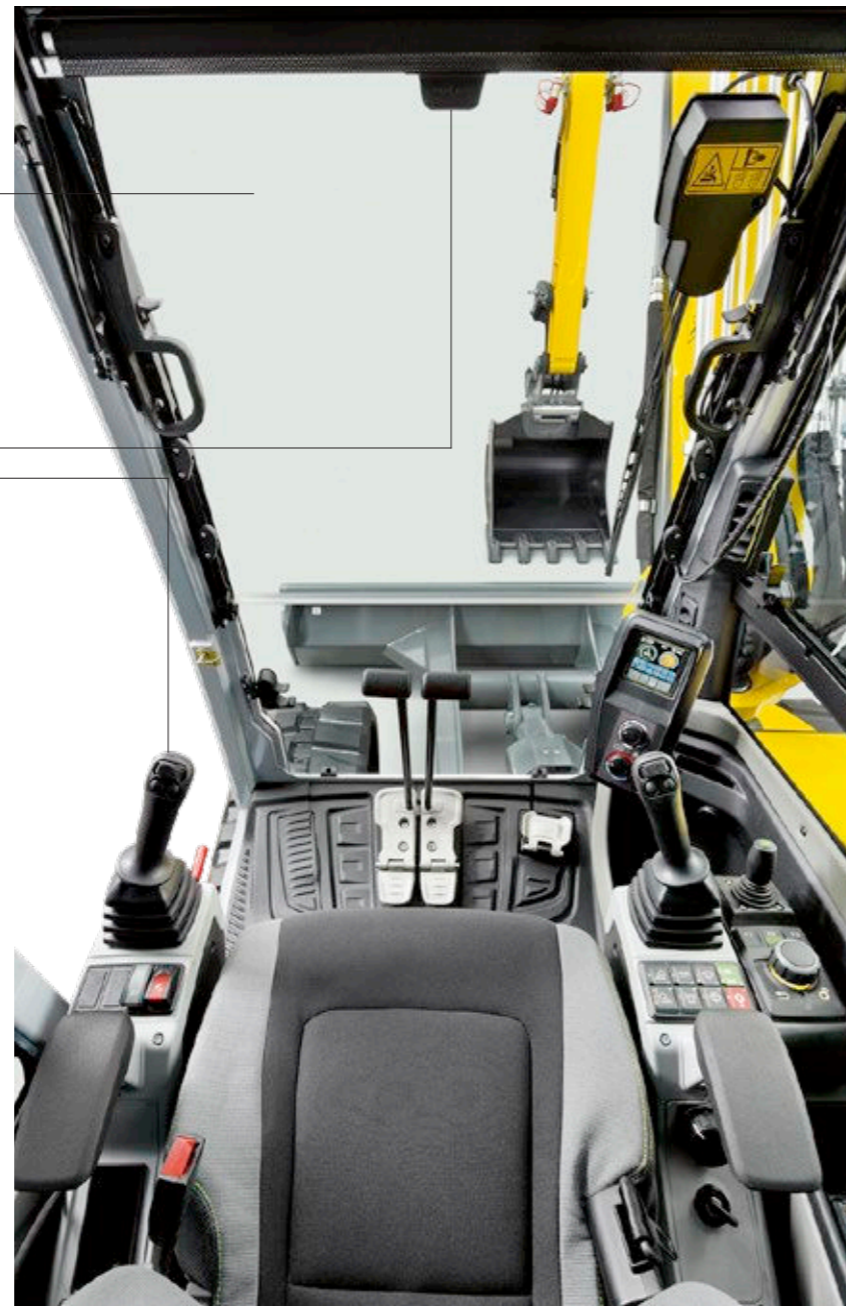

Innovative windshield system.

The two-part front window allows for optimal ventilation in the cabin in any weather. In addition, it makes it easier to

communicate with the operator. A separate removal and storage of the window is a thing of the past.

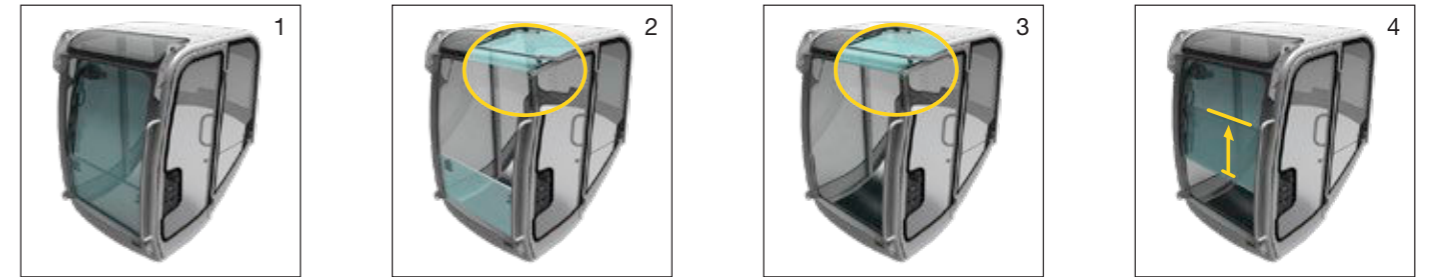

1. Closed front window - two glass windows keep water and wind out.

2. The upper front window can be pushed under the cabin roof. The lower pane serves as splash protection.

3. The lower window slides behind the upper window. Ideal for communication with colleague.

4. If necessary, both panes are pushed below the cabin roof where they are stored safely.

Default settings at the touch of a push button.

The Jog Dial system, familiar from the automotive area, including a clear display, providing the operator with intuitive selection of the right operating settings via a turn-push button, as well as

various settings via a keypad. With Jog Dial, you can, for example, save and access liter quantity or saving/retrieving release for attachments.





Individuality through variety.

Put together your perfect working unit from a variety of options available, such as:

- Up to 5 additional control circuits, of which 3 are individually adjustable
- Diesel particulate filter
- Air-cushioned seat with heated seat
- 7 LED lights
- 4 track versions
- Custom-made paint finish in automotive quality
- Rear-view camera
- Automatic air conditioning
- Counterweight
- Panolin hydraulic oil
- And much more

All-rounder on the job site: the tracked excavators ET65, EZ80, and ET90.



Simple maintenance. Simple repair.

The high productivity of our machines is not just due to the sturdy technology. Most service work can be completed in a short time due to quick and easily accessible maintenance points. Professional maintenance and repairs done by our technicians and original spare parts by Wacker Neuson also extend the service life of your machines.



Reduced dimensions.

Whether during transportation or in tight spaces: Thanks to their compact design, the ET65, EZ80 and the ET90 can easily be taken to your next job site. And on the job site, the machines can maneuver anywhere — even in confined spaces. You can benefit from high efficiency in all applications.

- Very low entry height
- Reduced dimensions due to the intelligent component arrangement
- Higher level of stability due to the low center of gravity

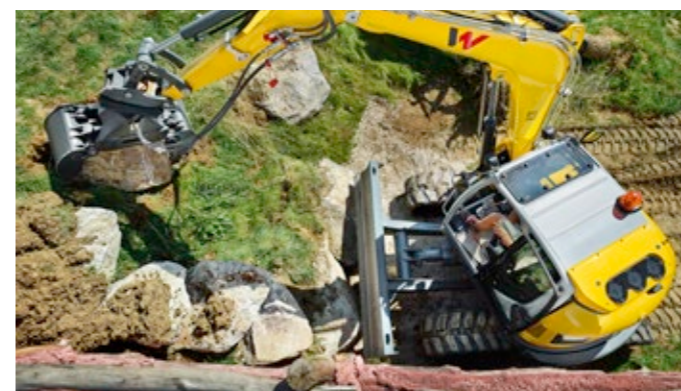

The EZ80 with minimal rear projection.

Enables safe and precise work directly up against walls and other obstacles on the construction site, and as a result a greater application range for the machine. Safety around the machine is also increased, therefore preventing damage.



Tool carrier with many application options.

Thanks to up to 5 auxiliary control circuits, the machines are ideally prepared for the application of a number of attachments, and can change them without a great deal of effort, within a short period of time in conjunction with a quick hitch system.



One of our largest compacts:
the tracked excavator ET145.

ET145

Shipping weight (kg)	14,917–15,701
Digging depth with short or long dipper stick (mm)	5,000–5,500
Engine output (kW)	55.4

Power, maneuverability, and stability.

An overview of all the ET145's features.

Comfort

- Comfortable, fully glazed cab
- Intuitive operating concept enables the simple and comprehensive control of the excavator using the Jog Dial and the display
- Large, multi-functional, 7-inch color display shows all functions and camera images
- Air-conditioning installed as standard

Maintenance

- Optimal maintenance access for quick, favorably-priced service
- Sturdy aluminum radiator improves the cooling performance, and is easy to clean
- Cabin is easy to remove to service and repair works

Safety

- Eight large tie-downs for safe transport
- Six LED work lights for optimal illumination of the work area

Versatility

- With AUX I auxiliary hydraulics diverse attachments can be used
- AUX II (3rd control circuit) optionally available
- Three track versions for any application



Environmental-friendliness

- Low noise emissions for easy communication on the construction site
- Lower emissions with the same performance due to the diesel particulate filter (no SCR necessary)

Efficiency

- Swivel console offers more flexibility in excavation work and saves time
- Jog Dial for intuitive selection of the correct operation settings via the turn-push button
- Extensive application options as a result of up to five additional control circuits ex works, of which three can be individually set
- Thermal stability enables 100% power with an ambient temperature of up to 45°C
- Three operating modes: ECO mode, HI mode, and LOW mode for different, very demanding tasks

Performance

- Constant power engine for full power at any working speed and low consumption
- Two pre-set operating modes: POWER or fuel-saving ECO mode
- Standard dozer blade for maximum lifting power and stability
- Two travel speeds
- Compact dimensions ensure for high level of safety during transportation and entry, as well as a high level of stability

The best of both worlds.

The ET145 combines the productivity of a large excavator model with the advantages of a compact excavator, such as:

- High maneuverability
- Easy transport
- Different track versions
- High digging power, such as with much larger excavators



The champion in the compact class: the tracked excavator ET145.

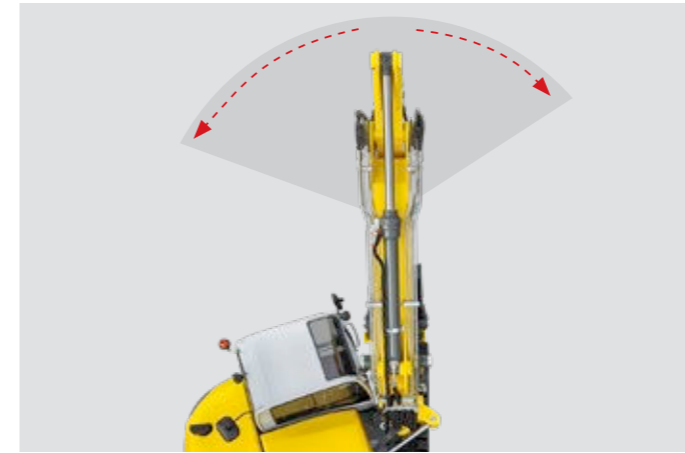

Swivel console for higher productivity.

The swivel console makes the ET145 into a real highlight in its weight class. This allows you an increased excavation range to the right and left. The swivel console enables work along walls, trenches, or obstacles, and improves the field of vision, for example with excavation work in trench areas.



Large, ergonomic comfort cabin.

Sitting position, armrests and joystick can be individually adjusted. The operator sees both the image of the rear-view camera and the programmable discharge volumes for the auxiliary control circuits on the large display, in addition to also seeing machine information. The Jog Dial can be comfortably operated from the seat position. The cab is equipped with automatic air-conditioning as standard.



Efficient engine.

The 55.4-kW-engine offers excellent digging power with low consumption and fulfills the current emission standards. As a result of the automatic idling speed control and the diesel particulate filter, consumption is reduced and the environment is protected.

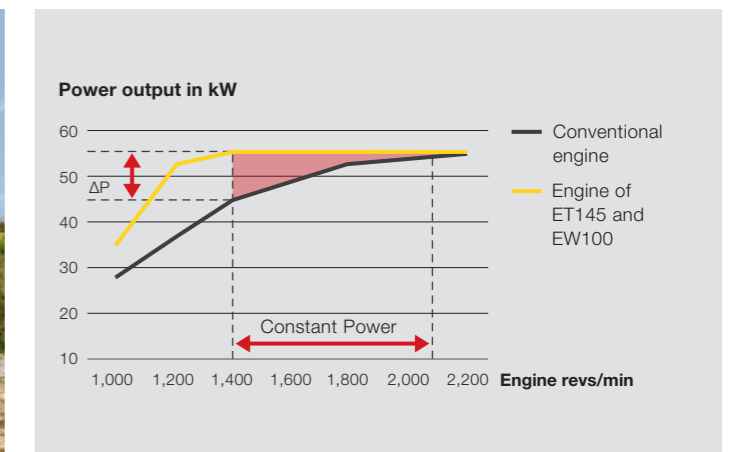

Full power even at low rpm.

Even at low speed the ET145's engine develops its full power, which it can then maintain. With this, it clearly has an advantage over the usual engines.



Power and speed, perfectly combined:
of the wheeled excavator EW65.

	EW65
Shipping weight (kg)	6,472–7,720
Digging depth with short or long dipper stick (mm)	3,596* – 3,895*
Engine output (kW)	42

* with articulated boom

Efficient and quick.

An overview of all the EW65's features.

Efficiency

- Articulated boom for bigger digging radius and less repositioning
- Optimal positioning of hydraulic components
- Powerful drive system for high performance
- Precise control with any load thanks to load-sensing hydraulic system with LUDV (load-independent flow distribution)
- Comprehensive application options due to up to four auxiliary control circuits ex works
- Thermal stability enables 100% power with an ambient temperature of up to 45°C

Performance

- 3-point kinematics improves the break out force, insertion depth and dumping height
- Two pre-set operating modes: POWER or fuel-saving ECO mode
- Closed travel circuit, variable from 0 to 30 km/h without gear selection

Environmental-friendliness

- Low noise emissions for easy communication on the job site
- Environmentally sound and sustainable due to diesel particulate filter (optional)



Comfort

- Low overall height
- Intuitive operating concept enables the simple and comprehensive control of the excavator
- Powerful automatic climate control
- Seat heating
- Innovative windshield system with rain cover function
- Extensively equipped, fully-glazed comfort cab
- Speed regulation system, ideal for municipal work, such as mowing, milling, and mulching

Maintenance

- Optimal maintenance access for quick, favorably-priced service
- Tilttable cabin and removable chassis cover for easy maintenance
- Durable aluminum radiator with high thermal stability, quick and easy to clean

Versatility

- Numerous attachments thanks to optional auxiliary control circuits
- Job site change on its own axle
- Up to 30 km/h
- Compact design for easy transportation and more application options

Safety

- LED work lights for optimal illumination of the work area
- 7-inch multifunction display incl. rear-view camera as standard
- Six large tie-downs for quick lashing down and secure transport
- Individual support versions: dozer blade or stabilizers, rear, front or both sides

More power and reach thanks to the 3-point kinematics.

The bucket pivot point and thus the torque increases due to an additional bolt in the joint (articulated) rod linkage. The advantage in numbers:

- Up to 20% higher break out force
- 5% greater insertion depth
- 10% greater dumping height



Captivating on any terrain: the wheeled excavator EW65.



Sophisticated working area.

Seat, armrests, and control lever position can be individually adjusted. Operation is both easy and intuitive - identical to the ET65. The proven front windshield system makes communication with the operator easier. To open completely, the windshield can be simply pushed under the cab roof and fixed there.



Increased stability.

A stable, good footing is essential - above all during heavy excavation work or on difficult ground conditions. For support, you can use a dozer blade or support stabilizers - both in front, in the rear, or in any combination.



More leeway thanks to articulated boom.

Optionally available with the EW65, the articulated boom, with a long or short dipper stick, provides you with more maneuverability and therefore greater freedom of action. So not only can you excavate deeper, but the additional joint also makes it possible to pull the bucket all the way to the travel gear or the dozer blade. Ideal when narrow spaces need to be accessed or an obstacle has to be moved out of the way.



Both powerful and sensitive.

Thanks to the load-sensing hydraulics with LUDV (load-independent flow distribution), the power can be adjusted to the situation.



Innovative thinking: the wheeled excavator EW100.

	EW100
Shipping weight (kg)	10,320 – 11,550
Digging depth with long dipper stick (mm)	4,968
Engine output (kW)	55/100

Developed for the job site 4.0.

An overview of all the EW100's features.

Efficiency

- Optimal positioning of hydraulic components
- Grade Assist automatic grading function assists the machine on the job site
- HMI (Human Machine Interface) saves different user settings and job site information clearly and efficiently
- Attachment interfaces prepared as standard to communicate with other devices in the construction process

Environmental-friendliness

- Auto-stop function turns the machine off if not in use
- ECO automatic in Street mode and ECO mode with intelligent power splitting in construction site operation
- Low-emission stage 5 engine with automatic rpm

Versatility

- Pallet fork operation ex works
- Preparations for 2D and 3D control units ex works
- Preparations for assistance systems and attachment control ex works, without necessary conversions



Safety

- 360° stability - even with high loads the machine remains stable in all directions
- Very good all-round visibility due to low engine hood, deep-glazed windows and doors, as well as visible load edge
- Active Working Signal (AWS) at rear signals starting up, attachment change, or machine braking when in Street mode
- Flexible piston rod protection protects against damage without needing to be changed
- Auto-brake function brakes automatically as soon as the foot is taken off the gas
- Entry, handles, and steps in signal color

Performance

- Highest performance in all areas, including strongly increased auxiliary hydraulics and engine output
- Trailer operation, braked for up to 12t payload
- 40 km/h maximum speed
- Joystick steering
- 3-point kinematics for 200° and 20% higher excavation specifications
- 20% more swing power for tilt-rotator applications

Comfort

- Thermal management with auto warm-up and auxiliary heating
- Removable toolbox, incl. power connection and tank filler points at ideal operating height
- Easy refuelling from the ground

Highest performance across all areas.

With its strong engine output, the EW100 generates the best data for acceleration and top-speed of up to 40 km/h. The increased auxiliary hydraulic output also enables the use of a number of attachments.

Sets new standards for the future: the wheeled excavator EW100.

Attachment interface.

The EW100 is equipped ex works for the retrofitting of an attachment interface. This enables an expansion to the machine software with future developments in the field of digitization,

without needing to perform retrofits to the machine itself. As a result, communication with attachments can be performed directly via the machine, and the construction process is optimized.



Preparations for assistance systems and attachment control units.

The machine is prepared ex works for any retrofitting of assistance systems or attachment control units. These can be retrofitted

through software updates with little effort. As a result, it is possible to avoid cost and time-intensive conversions.



Very good all-round visibility.

The design of the machine has been particularly optimized in terms of the field of visibility for the operator. For example, the right tire is very easy to see from the normal seating position. Among other things, this increases the safety for the operator and the job site surroundings.



Human Machine Interface.

The wheeled excavator EW100 stores individual settings and information for different operators and construction sites. The saved data can be retrieved by selection on the standard 10-inch touchscreen display and work can continue. The operator-

based machine settings store both personal key assignments for individual operating comfort, as well as attachment and flow rate settings per user.



360° stability.

Even at high weights, the machine stands firmly on the ground. As a result of the 360° stability, it is possible to move even large loads without the machine becoming unstable. Through

the optimal balance, the lateral stability of the machine is also increased by 25%.





Compact and powerful.

The EW100 combines the dimensions of a compact machine with the power of a 14-ton excavator. 20% more swing power for tilt rotator applications and the proven 3-point kinematics with swivel console ensure even more freedom of movement when in use.

200° bucket angle of rotation, 20% better excavation data, and as a result 360° stability make the EW100 one of the most powerful construction site aids.



Many attachments, minimal effort.

Simple select, attach, and get started. Attachments that are already saved can, in part, be automatically coupled and the operator need not leave the machine to do this. The machine

learns to recognize intelligent attachments and to communicate with them. Manual attachments can be stored once and then selected and recognized in future by just pressing on the display.

“Next level” of the wheeled excavator:
be best-equipped now for the future.



Attachment operation up to 12 tons.

Thanks to its powerful output, the EW100 is prepared for trailer operation (braked up to 12 tons). With this, there is no need for additional transportation vehicles for attachments or smaller machines.



Select and get started.

Attachments that have already been configured and manually saved can be easily and intuitively changed at any time. In doing so, the operator is guided by the specific saving and setting options.

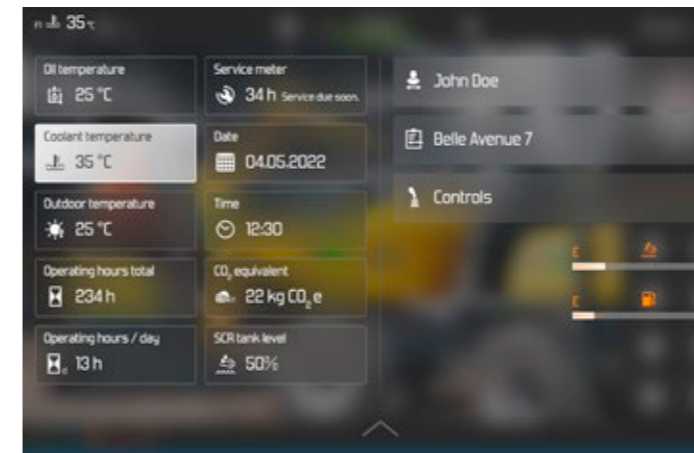

Customization made easy.

If desired, a specific user, the current job site, and specific joysticks can be configured to guarantee the ideal work cycle with the guarantee of comfort. Thus the operator has all the important details immediately available. Different job sites can be retrieved after entry, and all information on them can be retrieved.



Low in servicing and maintenance.

The increased maintenance intervals and an integrated self-check system greatly minimize the machine downtimes. If an error should arise, the performed troubleshooting saves high costs and via remote diagnostics can also provide information about the current machine status.

Attachments.

Quick hitch systems.



EasyLock+.

With the hydraulic quickhitch system EasyLock+, you can change the attachment from the operator's seat in just a few seconds by pressing the button. This makes you even more flexible and productive.

In addition to the normal bucket operation, the system also enables the use of a face shovel. Thus, the new EasyLock+ is even safer and meets all the requirements of current standards.



Powertilt.

The Powertilt swivel unit is available as an option and can be combined with both EasyLock+ and the Lehmatic quick hitch system. This allows the attachment to be tilted by up to 90° on each side – ideal for leveling, mulching, or grading work.

Lehmatic.

With the Lehmatic quick coupler system, you have the option to select between the mechanical and hydraulic system. The system is durable and functionally reliable, even for hard applications. The hydraulic system is equipped with "Double-Lock" safeguard. The Lehmatic quickhitch system is available both with and without the Powertilt.

The right attachment for every application.

Bucket types.

Wacker Neuson offers you different bucket types for excavating, separating, transporting and shaking off soils or other bulk materials. These are available for both EasyLock+ and Lehmatic quickhitch systems.

To be perfectly equipped for all situations from the outset, there are a number of pre-defined bucket sets available ex works. For more information, please contact your sales partner.



Bucket with blade



Bucket with teeth



Ditch or trench cleaning bucket



Swivel bucket incl. hydraulic hoses and couplings



Hydraulic breakers.

Our range of hydraulic breakers as attachments for mini excavators, compact excavators, and wheeled excavators is ideal for demolition and renovation work. The energy recovery system offers you a high level of productivity. The performance directly at the breaker is always maintained at a constant as a result of the innovative system and it has good reliability.



Grapples.

The grapple range is ideally tuned to our machines and provides extensive application options from gardening and landscaping to demolition work. Sorting & demolition grapples and multi-purpose grapples in different sizes will become available ex works.

Configuration options.

Cab

	ET65	EZ80	ET90	ET145	EW65	EW100
Side mirror (rear-view mirror)	●	●	●	●	●	●
FOPS protective grating level 1	●	●	●	○	●	●
FOPS protective grating level 2*	○	○	○	○	○	○
1-door cabin (sliding window)	●	●	●	●	●	●
Automatic air conditioning	○	○	●	●	○	●
Air-cushioned operator's seat	○	○	○	○	○	○
Air-cushioned, heated seat	-	-	-	-	-	○
Radio installation	●	●	●	-	●	●
Radio incl. Bluetooth intercommunication station	○	○	○	●	○	●
Sun shade	-	-	-	-	●	●
Auxiliary heating	-	-	-	-	-	○
10-inch touchscreen display	-	-	-	-	-	●

Hydraulics

	ET65	EZ80	ET90	ET145	EW65	EW100
Automatic pressure release H1 & H2 (AUX I + AUX II)	-	-	-	-	-	●
Electric pressure setting H1 & H2 (AUX I + AUX II)	-	-	-	-	-	○
Flat-faced coupler	○	○	○	○	○	○
Leak oil line	-	-	-	-	-	○
Panolin HLP Synt46 (Bio)	○	○	○	○	○	○
Auxiliary hydraulics proportional control (AUX I)	●	●	●	●	●	●
Flow control valve for auxiliary hydraulics	○	○	○	●	○	○
Flow control valve 3rd control circuit	○	○	○	○	○	○
Control circuit for grapple (AUX V)	○	○	○	○	○	●
Safe load indicator Basic	●	●	●	-	-	-
Overload warning device Advanced	○	○	○	●	●	●
Preparation for Powertilt (H3 / AUX III)	○	○	○	○	○	○
Preparation for quick coupler system (Q / AUX IV)	○	○	○	○	○	○
Auxiliary hydraulic circuit (H1 / AUX I)	○	○	○	●	○	●
Auxiliary hydraulic circuit (H2 / AUX II)	○	○	○	○	○	●
3rd control circuit (AUX II)	○	○	○	●	○	●

Paint

	ET65	EZ80	ET90	ET145	EW65	EW100
Special paint 1 RAL	○	○	○	○	○	○
Custom paintwork 1 no RAL	○	○	○	○	○	○
Special paint cab/canopy RAL	○	○	○	○	○	○

Security

	ET65	EZ80	ET90	ET145	EW65	EW100
Security 24 C (2,000 h)	○	○	○	○	○	○
Security 36 C (3,000 h)	○	○	○	○	○	○
Security 48 C (4,000 h)	○	○	○	○	○	○
Security 60 C (5,000 h)	○	○	○	○	○	○

Other

	ET65	EZ80	ET90	ET145	EW65	EW100
All-wheel steering	-	-	-	-	-	○
Trailer operation complete	-	-	-	-	-	○
Trailer operation preparation	-	-	-	-	-	○
Attachment interface	-	-	-	-	-	○
Work light mounted to boom	●	●	●	●	●	●
Front and rear work lights	○	○	○	●	○	●
Auto-break function	-	-	-	-	-	●
Auto-stop function	-	-	-	-	-	○
Auto-warm-up function	-	-	-	-	-	○

* only with additional protective grate ● standard ○ option - not available

Other

	ET65	EZ80	ET90	ET145	EW65	EW100
AWS (Active Working Signal)	-	-	-	-	-	●
Counterweight	○	○	○	-	-	-
Balloon tires	-	-	-	-	●	○
Diesel filling pump	○	○	○	●	○	○
Automatic RPM speed control	●	●	●	●	●	●
EquipCare 36 months (including app & manager)	○	○	○	○	○	○
Drive signal	○	○	○	-	○	○
Speed regulating system	-	-	-	-	○	○
Rubber track*	●	●	●	○	-	-
Hybrid track*	○	○	○	○	-	-
Joystick steering	-	-	-	-	-	○
LED lighting	○	○	○	-	○	○
Long dipper stick	○	○	○	○	○	●
Optional joystick with option to configure	-	-	-	-	-	○
Pallet fork operation complete	-	-	-	-	-	○
Pallet fork operation preparation	-	-	-	-	-	●
Front or rear dozer blade	-	-	-	-	○	○
Front or rear stabilizer support	-	-	-	-	○	○
Rearview camera	○	○	○	●	●	●
Reverse alarm	-	-	-	-	-	○
LED rotating beacon	○	○	○	○	○	○
Green LED rotating beacon	-	-	-	-	-	○
Bucket cylinder hose breakage protection	-	-	-	-	-	○
Dirt trap	-	-	-	-	-	○
Lifting arm vibration dampening	-	-	-	-	-	○
Steel track*	○	○	○	●	-	-
Road traffic regulation accessories	-	-	-	-	○	○
ISO - SAE switch-over	○	○	○	○	○	○
Steering logic switch-over	-	-	-	-	-	○
Articulated boom	○	-	○	-	○	●
Assistance systems' operation	-	-	-	-	-	●
KAT immobilizer system	○	○	○	○	○	○
Tool box	-	-	-	-	-	○
Central lubrication system	-	-	-	-	-	○
Dual tires	-	-	-	-	○	●
Twin tires with intermediate ring	-	-	-	-	-	○
30 km/h	-	-	-	-	○	○
40 km/h	-	-	-	-	-	○

Assembled attachments

	ET65	EZ80	ET90	ET145	EW65	EW100
Easy Lock	○	○	○	-	○	○
Easy Lock + Powertilt	○	○	○	-	○	○
Easy Lock + Powertilt + load hook	○	○	○	-	○	○
Hyd. Lehnhoff quick hitch system + load hook	○	○	-	○	○	○
Hyd. Lehnhoff quick hitch system + Powertilt + load hook	○	○	-	○	○	○
Mechanical quick hitch system	○	○	○	○	○	○
OilQuick + load hook	-	-	-	○	-	○
OilQuick + Powertilt + load hook	-	-	-	○	-	○

* different widths possible depending on model ● standard ○ option - not available

Dimensions.

	Unit	ET65	EZ80	ET90	ET145	EW65	EW100
A Height	mm	2,478	2,562	2,562	2,790 2,825 ⁽⁴⁾	2,775	2,963
B Width of travel gear, retracted (track / tires)	mm	1,950	2,250	2,250	2,490	1,832 2,088 ⁽¹⁾	2,450
C Transport length (short dipper stick)	mm	6,128 6,100 ⁽³⁾	6,939	7,117 6,468 ⁽³⁾	7,720	6,114 6,220 ⁽³⁾	-
C Transport length (long dipper stick)	mm	6,135 6,210 ⁽³⁾	6,944	7,139 6,690 ⁽³⁾	7,790	6,137 6,349 ⁽³⁾	6,707
D Max. digging depth (short dipper stick)	mm	3,757 3,879 ⁽³⁾	3,919	4,325 4,379 ⁽³⁾	5,000	3,531 3,596 ⁽³⁾	-
D Max. digging depth (long dipper stick)	mm	4,003 4,184 ⁽³⁾	4,169	4,625 4,679 ⁽³⁾	5,500	3,831 3,895 ⁽³⁾	4,968
E Max. vertical insertion depth (short dipper stick)	mm	2,431 2,811 ⁽³⁾	1,915	3,192 3,198 ⁽³⁾	3,100	2,088 2,465 ⁽³⁾	-
E Max. vertical insertion depth (long dipper stick)	mm	2,704 3,095 ⁽³⁾	2,124	3,474 3,456 ⁽³⁾	3,600	2,361 2,737 ⁽³⁾	3,039
F Max. insertion height (short dipper stick)	mm	5,759 6,539 ⁽³⁾	6,620	7,322 7,931 ⁽³⁾	8,300 ⁽⁵⁾	6,068 6,834 ⁽³⁾	-
F Max. insertion height (long dipper stick)	mm	5,940 6,774 ⁽³⁾	6,782	7,529 8,196 ⁽³⁾	8,600 ⁽⁵⁾	6,250 7,067 ⁽³⁾	8,069
G Max. dumping height (short dipper stick)	mm	3,993 4,684 ⁽³⁾	4,587	5,066 5,674 ⁽³⁾	5,700 5,659 ⁽⁴⁾	4,207 4,961 ⁽³⁾	-
G Max. dumping height (long dipper stick)	mm	4,714 4,916 ⁽³⁾	4,749	5,272 5,940 ⁽³⁾	6,000	4,389 5,195 ⁽³⁾	6,260
H Max. digging radius (short dipper stick)	mm	6,224 6,601 ⁽³⁾	6,955	7,331 7,596 ⁽³⁾	8,300	6,220 6,590 ⁽³⁾	-
H Max. digging radius (long dipper stick)	mm	6,508 6,890 ⁽³⁾	7,190	7,620 7,889 ⁽³⁾	8,800	6,504 6,877 ⁽³⁾	7,713
I Max. reach at ground level (short dipper stick)	mm	6,100 6,487 ⁽³⁾	6,795	7,179 7,463 ⁽³⁾	8,100	6,024 6,406 ⁽³⁾	-
I Max. reach at ground level (long dipper stick)	mm	6,391 6,779 ⁽³⁾	7,036	7,474 7,751 ⁽³⁾	8,600	6,318 6,706 ⁽³⁾	7,503
J Min. tail swing radius	mm	1,363	1,228	1,583	2,015	1,459	1,690
K Max. boom offset to center of bucket (right/left)	mm	766/ 492	705/ 683	705/ 683	850/ 640	766/ 492	940/ 625
L Max. stacking height of the dozer blade above subgrade (short/long)	mm	403	474	479	492/ 532 ⁽⁴⁾	395	390
M Max. scraping depth of dozer blade under subgrade (short/long)	mm	427	523	518	531/ 493 ⁽⁴⁾	301	136
N Total track length	mm	2,516	2,826	2,826	3,605	2,887	3,193
O Max. swing angle of arm system to the right	°	63	63	63	57	63	55
P Max. swing angle of arm system to the left	°	67	67	67	70	67	70
Q Track/tire width	mm	400	450	450	500	300/ 457 ⁽¹⁾	490 / 514 / 577
R Boom swing radius, center	mm	2,453 3,159 ⁽³⁾	2,869	2,503 2,840 ⁽³⁾	2,814	2,465 2,605 ⁽³⁾	3,141

⁽¹⁾ Dual tires ⁽²⁾ Balloon tires ⁽³⁾ with articulated boom ⁽⁴⁾ with hybrid track ⁽⁵⁾ with steel track

Technical data.

General

	Unit	ET65	EZ80	ET90	ET145	EW65	EW100
Shipping weight	kg	5,806–6,682	7,588–8,877	8,348–9,625	14,917–15,701	6,472–7,720	10,320–11,550
Operating weight	kg	6,078–7,358	7,918–9,544	8,710–10,506	15,551–17,275	6,755–8,647	10,625–11,855
Max. ripping force*	kN according to ISO 6015	30.8	43.7	46	69	30.8	44
Max. break out force	kN according to ISO 6015	50.7	68	73.8	91	50.7	73.3

Engine

	Unit	ET65	EZ80	ET90	ET145	EW65	EW100
Drive output	according to ISO kW/hp	42/ 57.1	42/57.1	55.4/75.3	55.4/ 75.3	42/ 57.1	55/ 75 100/136
Fuel tank volume	l	85	85	85	205	85	190
Emission standard	-	Stage V					

Hydraulics

	Unit	ET65	EZ80	ET90	ET145	EW65	EW100
Hydraulic system / pumps	-	LUDV with variable displacement pump			Negative control with dual displacement pump and 2 gear pumps	LUDV with variable displacement pump, separate travel pump	
Max. flow rate	l/min	144	160	175	2x118+20+36	158.4+99	181.5 + 32.9 170 + 171
Operating pressure for work and drive hydraulics	bar	240	300	300	340	240/420	300
Operating pressure for swing gear	bar	215	240	240	320	215	280
Auxiliary hydraulics, max. discharge volume	l/min	107	113	113	121	107	180

Travel gear

	Unit	ET65	EZ80	ET90	ET145	EW65	EW100
Ground clearance	mm	284	357	370	480	237	293 / 301 / 310
Max. travel speed	km/h	5.2	4.4	5	5	up to 30	40
Ground pressure of basic machine	kg/cm ²	0.35	0.36	0.40	0.50	-	-

Noise emissions

	Unit	ET65	EZ80	ET90	ET145	EW65	EW100
Sound power level (LWA)	dBA acc. to 2000/14/EC	97	97	99	99	97	99
Emission sound pressure level (LPA)	dBA acc. to ISO 6394	77	79	79	75	77	tba

All information relates to the base machine. Subject to changes.

Tracked excavators

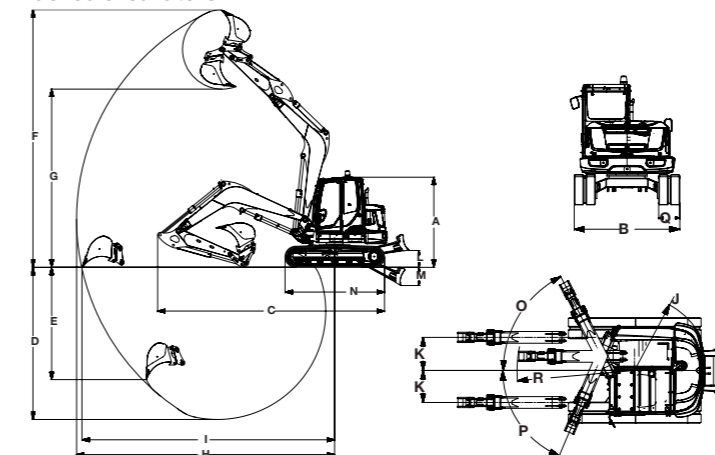

Wheeled excavators

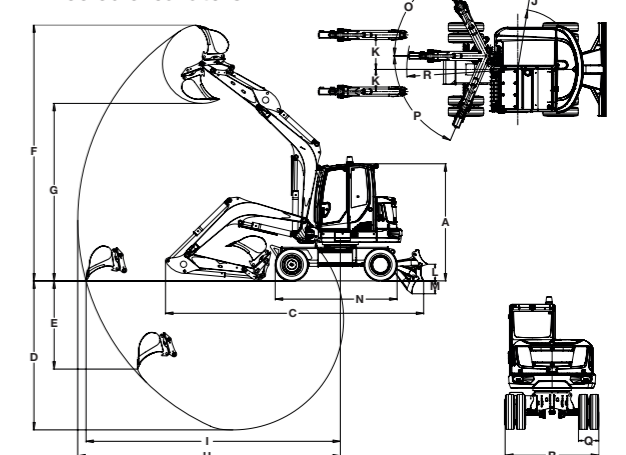

Lift capacity tables.

ET65

A	MAX																													
	5.0 m				4.0 m				3.0 m				2.0 m																	
	C		D		C		D		C		D		C		D															
B	Blade up		Blade down		Blade up		Blade down		Blade up		Blade down		Blade up		Blade down															
	from	up to	from	up to	from	up to	from	up to	from	up to	from	up to	from	up to	from	up to														
4.0 m	817	1,291*	1,099	1,291*	663	1,144	840	1,011	1,095	1,095*	683	833	1,060	1,244*	1,060	1,244*	936	1,244*	-	-	-	-	-	-	-	-				
3.0 m	672	1,080*	1,150	1,280*	535	902	794	1,043	1,086	1,149*	669	871	1,115	1,308*	1,115	1,308	1,002	1,262	1,580	1,580*	1,580	1,580*	1,580	1,580*	-	-	-	-	-	-
2.0 m	593	955*	1,121	1,301*	471	797	753	1,021	1,157	1,313*	639	850	1,145	1,446	1,341	1,474	923	1,208	1,621	2,090	1,621	2,090*	1,431	1,852	2,751	2,751*	2,751	2,751*	2,751	2,751*
1.0 m	562	915*	1,105	1,339*	443	758	722	993	1,238	1,401*	597	822	1,056	1,383	1,600	1,738	838	1,138	1,602	2,140	2,350	2,549*	1,241	1,723	3,447	4,183	4,277	4,597*	2,508	3,086
0 m	569	938*	1,009	1,387*	446	776	716	972	1,271	1,441*	561	804	991	1,331	1,703	1,908	776	1,090	1,515	2,028	2,539	2,856*	1,160	1,622	2,850	4,092	4,362	5,419*	2,237	3,080
-1.0 m	619	1,048*	984	1,437*	486	864	697	952	1,131	1,360*	545	784	959	1,314	1,605	1,894	746	1,074	1,486	2,010	2,273	2,812*	1,132	1,605	3,130	4,149	3,240	5,007*	2,235	3,085
-2.0 m	749	1,356*	911	1,456*	585	1,112	-	-	-	-	-	-	969	1,308	1,227	1,639	755	1,068	1,510	2,041	1,744	2,461*	1,155	1,633	2,363	4,125*	2,363	4,125*	2,300	3,148

All table values are given in kg in a horizontal position on a solid surface and without bucket.

EZ80

A	MAX																														
	5.0 m				4.0 m				3.0 m				2.0 m																		
	C		D		C		D		C		D		C		D																
B	Blade up		Blade down		Blade up		Blade down		Blade up		Blade down		Blade up		Blade down																
	from	up to	from	up to	from	up to	from	up to	from	up to	from	up to	from	up to	from	up to															
4.0 m	905	1,173	1,949	2,094*	987	1,287	1,048	1,235	1,900	2,074*	1,143	1,368	1,588	1,806	2,043	2,043*	1,713	1,999	-	-	-	-	-	-	-	-	-	-	-	-	-
3.0 m	766	991	1,946	2,079*	834	1,086	1,030	1,217	1,996	2,131*	1,124	1,341	1,496	1,744	2,140	2,340*	1,648	1,950	-	-	-	-	-	-	-	-	-	-	-	-	
2.0 m	729	904	2,069	2,098*	797	991	983	1,170	2,224	2,336*	1,076	1,288	1,392	1,640	2,677	2,859*	1,538	1,837	2,155	2,574	3,752	4,164*	2,441	2,934	-	-	-	-	-	-	-
1.0 m	668	875	2,008	2,134*	731	961	932	1,119	2,467	2,546*	1,017	1,234	1,288	1,536	3,217	3,346*	1,429	1,717	1,929	2,317	5,041	5,275*	2,196	2,656	-	-	-	-	-	-	-
0 m	682	899	2,054	2,176*	747	989	894	1,081	2,607	2,637*	970	1,195	1,211	1,470	3,513	3,561*	1,349	1,645	1,832	2,216	5,417	5,417*	2,094	2,545	-	-	-	-	-	-	-
-1.0 m	746	993	2,094	2,206*	819	1,096	882	1,069	2,530	2,470*	949	1,183	1,178	1,448	3,415	3,462*	1,314	1,621	1,807	2,208	4,975	5,131*	2,066	2,536	3,712	4,517	8,173	9,014*	4,594	5,615	
-2.0 m	909	1,236	2,092	2,165*	1,002	1,372	-	-	-	-	-	-	1,188	1,469	2,780	2,979*	1,324	1,643	1,834	2,246	4,000	4,311*	2,095	2,577	3,791	4,598	6,240	7,144*	4,686	5,711	

ET90

A	MAX																														
	6.0 m				5.0 m				4.0 m				3.0 m																		
	C		D		C		D		C		D		C		D																
B	Blade up		Blade down		Blade up		Blade down		Blade up		Blade down		Blade up		Blade down																
	from	up to	from	up to	from	up to	from	up to	from	up to	from	up to	from	up to	from	up to															
4.0 m	1,026	1,568	1,624	1,847*	960	1,383	1,083	1,265	1,621	1,621*	1,013	1,173	1,511	1,857*	1,702	1,857*	1,409	1,649	1,769	2,016*	1,769	2,016*	1,769	2,016*	-	-	-	-	-	-	-
3.0 m	903	1,369	1,567	1,818*	845	1,207	1,069	1,251	1,633	1,715*	999	1,159	1,459	1,826*	1,823	1,964*	1,358	1,606	2,073	2,294*	2,073	2,294*	1,942	2,252	2,488	3,028*	2,488	3,028*	2,488	3,028*	
2.0 m	839	1,272	1,528	1,814*	784	1,119	1,030	1,212	1,695	1,753*	962	1,124	1,383	1,759	1,995	2,145*	1,285	1,542	1,948	2,470	2,515	2,681*	1,790	2,146	3,139	3,809	3,402	3,943*	2,813	3,296*	
1.0 m	816	1,241	1,493	1,821*	763	1,089	988	1,170	1,747	1,778*	922	1,089	1,309	1,693	2,145	2,309*	1,213	1,479	1,808	2,337	2,831	3,032*	1,657	2,019	2,850	3,595*	4,166	4,625*	2,546	3,027	
0 m	833	1,272	1,452	1,828*	778	1,114	956	1,138	1,733	1,718*	890	1,066	1,258	1,647	2,200	2,369*	1,154	1,435	1,720	2,254	2,937	3,155*	1,572	1,941	2,657	3,477	4,209	4,636*	2,366	2,919	
-1.0 m	892	1,382	1,377	1,820*	832	1,209	946	1,128	1,574	1,574*	881	1,041	1,239	1,628	2,104	2,251*	1,126	1,417	1,680	2,227	2,736	3,057*	1,534	1,916	2,964	3,469	3,707	4,368*	2,349	2,912	
-2.0 m	1,040	1,640	1,257	1,756*	968	1,430	-	-	-	-	-	-	1,254	1,649	1,778	1,778*	1,134	1,438	1,689	2,241	2,252	2,708*	1,543	1,929	2,676	3,484*	2,955	3,757*	2,384	2,946	

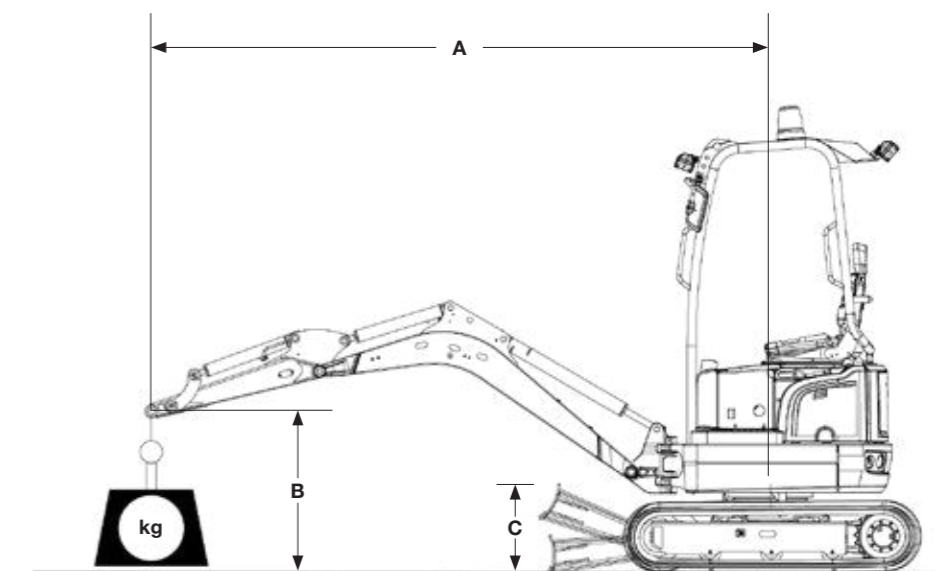

Meaning of abbreviations in tables

- A: Outreach from middle of rotating assembly
- B: Height of load hook
- MAX: Permissible load with extended dipper stick
- C: Dozer blade up or down, in travel direction – except EW100: against travel direction
- D: Dozer blade up, revolving superstructure 90° to travel direction

* Lift capacity limited by hydraulics

Actual lift capacity depends on the outfitting of the machine. You can find these in the respective operator's manual.

ET145

A	MAX																														
	6.0 m				5.0 m				4.0 m				3.0 m																		
	C		D		C		D		C		D		C		D																
B	Blade up		Blade down		Blade up		Blade down		Blade up		Blade down		Blade up		Blade down																
	from	up to	from	up to	from	up to	from	up to	from	up to	from	up to	from	up to	from	up to															
6.0 m	2,368	2,878	2,879	3,271*	2,544	3,094	-	-	-	-	-	-	2,569	2,946	2,569	3,234*	2,569	3,167*	-	-	-	-	-	-	-	-	-	-	-	-	-
4.0 m	1,677	1,909	2,966	3,301*	1,807	2,055	2,145	2,200	2,874	3,263*	2,307	2,365	2,862	2,893	2,866	3,349*	2,866	3,113*	3,572*	3,572*	3,572*	3,572*	3,572	3,572*	-	-	-	-	-	-	-
3.0 m	1,462	1,664	3,485	3,152*	1,580	1,775	2,015	2,050	3,545	3,828*	2,175	2,213	2,605	2,671	4,142	4,543*	2,818	2,827	3,528	3,660	5,370	6,064*	3,836	3,977	-	-	-	-	-	-	-
0 m	1,471	1,668	3,413	3,758*	1,594	1,805	1,884	1,927	4,182	4,303*	2,043	2,087	2,408	2,448	5,234	5,400*	2,617	2,659	3,247	3,293	7,159	7,333*	3,550	3,598	4,891	5,002	10,898*	11,140*	5,416	5,534	
-2.0 m	1,772	2,093	3,752	4,094*	1,921	2,269	1,858	1,883	4,029	4,029*	2,016	2,044	2,355	2,443	4,992	5,217*	2,563	2,654	3,201	3,308	6,629	6,958*	3,502	3,614	4,927	5,096	9,238*	10,030*	5,453	5,632	
-4.0 m	3,520	3,562	4,038	4,038*	3,837	3,884	-	-	-	-	-	-	-	-	-	-	-	-	-	-	-	-	-	-	-	5,240	5,302	5,812*	5,812*	5,812*	

EW65

A	MAX																														
	5.0 m				4.0 m				3.0 m				2.0 m																		
	C		D		C		D		C		D		C		D																
B	Blade up		Blade down		Blade up		Blade down		Blade up		Blade down		Blade up		Blade down																
	from	up to	from	up to	from	up to	from	up to	from	up to	from	up to	from	up to	from	up to															
4.0 m	1,019	1,227*	1,083	1,227*	726	1,207	1,079	1,079*	1,079	1,079*	806	883	1,125	1,240*	1,125	1,240*	1,125	1,240*	-	-	-	-	-	-	-	-	-	-	-	-	-
3.0 m	869	1,229*	1,047	1,229*	614	1,002	1,105	1,226*	1,105	1,226*	782	1,009	1,255	1,360*	1,255	1,360*	1,132	1,252*	1,523	1,721*	1,523*	1,721*	1,523	1,721*	-	-	-	-	-	-	-
2.0 m	798	1,255*	1,031	1,255*	559	914	1,186	1,281*	1,186	1,281*	746	984	1,466	1,554*	1,466</																

Wacker Neuson – all it takes.



Concrete technology



Vibratory rammers



Vibratory plates



Rollers



Demolition technology



Generators



Lighting



Pumps



Excavators



Wheel loaders



Telehandler



Dumpers



Financial solutions



Repair & Maintenance



Academy



EquipCare & EquipCare Pro



Rental



Concrete specialists



eStore



Spare parts



Used machines



ConcreteTec

